



Repairs handbook

A guide for tenants



Gas safety procedure

Can you smell gas?

- X Don't turn electric switches on or off.
- X Don't smoke.
- X Don't use naked flames.
- ✓ Do turn off the gas supply at the meter.
- ✓ Do open doors and windows to get rid of the gas.

Call the National Gas Emergency Service Freephone any time on

0800 111 999



If you are deaf or hard of hearing, use the minicom/textphone on 0800 37 17 87.

We service the gas appliances we have provided every 12 months. Please make sure you give us access at the right time.

Mains gas on and off lever

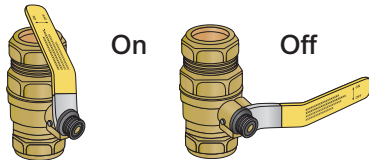

The gas shut-off tap is normally next to your gas meter. It would also be helpful if you can write down where the electric fuse board and water shut-off tap are.

Gas shut-off tap is:

The electric fuse board is:

The water shut-off tap is:

Tendring

District Council



Tendring District Council is constantly looking for ways to improve its service for its tenants.

This handbook aims to make it easier and quicker for you to report any repairs by including easy-to-use diagrams and clear explanations of some common repair problems. By using it whenever you report a repair, you can help us identify your repair and put it right first time. Simply find the item that you have a problem with and quote the reference number to our maintenance staff when reporting your repair. However, the handbook can't cover every problem, so sometimes we will need to visit your home before ordering the repair.

We hope you find the handbook useful and would welcome your comments.

Gas safety procedure	Inside front cover	Locks and fittings	36
How do I report a repair?	3	Outside of the property	37–40
What priority will my repair be given?	3	Roofs	41–42
Who will do my repair?	4	Stairs	43
What if I am out when the operative calls?	4	Toilets	44
Customer care	4	Windows	45
Repair responsibilities	5–11	Helpful advice	
Compliments and complaints	12	What is condensation?	46
Repairs we can charge you for	12	Condensation and mould growth	46–47
The Right to Repair scheme	12	How to guard against frost	47–48
The Right to Improve your Home	12–13	What to do if you get a frozen pipe	48
The Right to Compensation for Improvements	13	What to do if you have a burst pipe	48
The Right to Buy	13	What to do if you have a gas leak	49
How to use the following pages	13	Gas safety checks	49
Diagrams		Carbon monoxide	49
Basins and sinks	14–15	Central heating servicing	50
Baths and showers	16–17	Fire safety	51
Door repairs	18–19	If you have an electrical fault and have lost your supply	51–52
Downpipes and gutters	20–21	Resetting a trip switch	52–53
Drainage	22	Smoke alarms	54
Electrics	23–26	Blockages	54–55
Floors, walls and ceilings	27–28	Preventing Legionnaires Disease	55–56
Garages	29	Save £££s with these energy-saving tips	56
Glazing	30–31	Checking electrics	Inside back cover
Heating and hot water	32–34	Where to find equipment	Outside back cover
Kitchen units	35		

How do I report a repair?

You can find details of how to report a repair on our Contacting us information sheet or on our website.

When you report a repair, please give the following information:

- Your name, address, phone number or email address where we can contact you.
- Whether you would like our contractor to arrange a specific appointment with you.
- The times and dates that we will be able to call at your property to carry out a repair or inspection.
- As much detail as you can about the repair. If you phone us to report it, please have this handbook with you when you call.

For straightforward repairs, we will be able to order the repair as soon as you report it to us. However, if it is not clear exactly what is needed, we will arrange to visit your home, normally within 10 working days of you reporting the problem to us. We may also visit

your home after the repair has been completed to check it has been done properly.

What priority will my repair be given?

We give all repairs reported to us a priority rating that sets out when the works should be completed. The priority we give your repair will depend on how urgent it is. Examples of our response times are as follows:

Priority 0 – Emergency call-out (within 3 hours)

Priority 1 – Within 24 hours

Priority 2 – Within 48 hours

Priority 3 – Within 72 hours

Priority 4 – Within 7 calendar days

Priority 5 – Within 14 calendar days

Our priority categories go up to priority 8, which is a response time of 56 days for low priority repairs.

Who will do my repair?

The work will normally be done by our maintenance contractors. Their vehicles will display a logo showing they are working for us. Their employees will carry ID cards and wear protective clothing, also showing they are working for us. For some types of work or repairs, we will use a specialist contractor, for example for repairs to or servicing of gas central heating boilers.

Always make sure that anyone visiting your property on our behalf shows you their ID. A genuine caller will not mind you checking. If you are not sure whether a person is working for us, do not let them into your home. Please phone us or the police if you have any doubts.

What if I am out when the operative calls?

If you would like a specific appointment, please tell us this when you report your repair. We will then ask our contractor to contact you to arrange a date and time. Our contractors must keep all the appointments they make. However, if they cannot get into your home, we may cancel the repair and you will need to contact us again and request another appointment.

Customer care

Tendring District Council is committed to providing the highest level of service to you. To help us achieve this, we monitor our performance through, for example, customer satisfaction surveys that show us how we are doing. We will publish the results of these surveys in our newsletter.

The following tables show who is responsible (us or you) for repairing certain items.

Item	Us	You	Exceptions
Back boilers	✓		
Balcony	✓		
Banisters and handrails	✓		
Baths	✓		We may charge you for clearing a blockage if you have caused this by putting inappropriate items down the waste.
Bathroom accessories (toilet roll holder, towel rail and mirrors)		✓	
Blinds, blind fittings and cords		✓	We are responsible for these items in communal areas of our sheltered housing schemes.
Brickwork (including air bricks)	✓		
Ceilings	✓		Other decoration work inside your home, which includes filling minor cracks in plaster or similar materials.
Chimneys (including pots and covers)	✓		
Chimney sweeping (open fires)		✓	
Clothes-lines and rotary driers (communal)	✓		Clothes lines or driers installed by you or in individual gardens.
Coal bunkers	✓		A coal bunker you have supplied.
Cookers		✓	We are responsible for cookers we have provided in our sheltered housing schemes.
Damp-proof course	✓		
Disabled adaptations	✓		Equipment installed by Social Services, or portable equipment.

Repair responsibilities

Item	Us	You	Exceptions
Decoration inside the home, including minor cracks in plaster		✓	
Doorbells		✓	
Door fittings (including handles, letterboxes and locks)	✓		
Doors inside your home	✓		Any damage caused by you or someone living in or visiting your home.
Doors into the property and their door frames	✓		If the repair is needed because of vandalism or a burglary, you need to get a crime number from the police.
Downpipes	✓		
Drainage (external, including blockages)	✓		We may charge you for clearing blockages if you have caused them by putting inappropriate items into the drainage system.
Driveways	✓		Any driveway you have constructed.
Drying areas	✓		
Electric heating and fires	✓		We are not responsible for heating you have installed.
Electric plugs		✓	
Electric wiring (including sockets and switches)	✓		We are not responsible for any wiring (including sockets and switches) you have installed.
Electricity supply and meter, power cuts		✓	
Entry systems	✓		
Extractor fans	✓		Any extractor fans you have installed.
Fences	✓		Any fences you put up and any fences belonging to an owner-occupier next door.

Item	Us	You	Exceptions
Fire grates and surrounds	✓		
Fires (gas or electric)	✓		Any fire you have installed.
Floorboards	✓		
Floor tiles	✓		Any floor tiles you have installed.
Fluorescent strip lights	✓		Any fluorescent strip lights you have installed.
Foundations	✓		
Fridges		✓	We are responsible for those we have provided in our sheltered housing schemes.
Furniture and carpets		✓	We are responsible for those we have provided in the communal areas of our sheltered housing schemes.
Fuse boxes	✓		
Fuses in plugs		✓	
Garages	✓		
Garage locks	✓		
Garden sheds		✓	We are responsible if we have provided the shed.
Garden walls	✓		Walls or any other garden features you have built or installed.
Gas central heating (including flues, water pipes, radiators, timers and pumps)	✓		Any gas central heating you have installed.
Gas pipes	✓		
Gas supply and meter		✓	
Gates	✓		Any gates you have installed.

Repair responsibilities

Item	Us	You	Exceptions
Glass inside the home	✓		If the repair is needed because of damage caused by you or anyone who lives with or is visiting you, we may charge you for this. If the damage is caused by vandalism or burglary, you need to get a crime number from the police.
Glass to outside windows and doors	✓		If the repair is needed because of damage caused by you or anyone who lives with or is visiting you, we may charge you for this. If the damage is caused by vandalism or burglary, you need to get a crime number from the police.
Greenhouses		✓	
Guttering	✓		
Immersion heaters	✓		
Keys – replacement		✓	If you have a crime number from the police, we will not make a charge for replacing the keys.
Keys – replacement (communal)	✓		If you have a crime number from the police, we will not make a charge for replacing the keys.
Kitchen cupboards	✓		Cupboards you have provided.
Kitchen worktops (including sinks)	✓		Any worktops and sinks you have provided.
Lifts	✓		
Light bulbs		✓	
Light holders (including light fittings)	✓		
Lighting to shared corridors and stairs	✓		

Item	Us	You	Exceptions
Locks replacing	✓		
Loft hatches	✓		
Manhole covers and frames	✓		
Oil-fired boilers	✓		
Outbuildings	✓		If you ask us to replace a lock or key, we may charge you for this unless you have a crime number from the police.
Overflows	✓		
Painting inside the home, including minor cracks in plaster		✓	
Parking areas (communal)	✓		
Paths	✓		Any paths you have built.
Plaster	✓		Filling minor cracks, holes or small defects in plaster or similar materials.
Plugs or chains for sinks, washbasins or baths	✓		
Porch	✓		Any porch you have provided.
Pumps	✓		
Rendering (rough plaster on the outside of homes)	✓		
Roofing (including tiles or ridges)	✓		Any roof on a building you have constructed.
Roof lights (skylights)	✓		
Ropes for windows (sash cords)	✓		

Repair responsibilities

Item	Us	You	Exceptions
Shower and shower tray	✓		Any showers you have provided.
Sink or washbasin (blockages)	✓		We may charge you for clearing blockages if you have caused them by putting inappropriate items down the waste.
Skirting boards	✓		
Smoke detectors (mains-powered)	✓		Any battery-powered smoke alarms you have installed.
Solid-fuel central heating (including flues, water pipes, radiators, timers and pumps)	✓		Any heating you have installed.
Stairs	✓		
Steps to front or back doors	✓		
Taps	✓		
Toilet bowls	✓		We may charge you if the toilet bowl is damaged or blocked through misuse.
Toilet seats	✓		
Tumble driers (including vents)		✓	We are responsible for the vent if we have installed it to help you tackle condensation.
TV aerial or satellite dishes (and connections)		✓	We are responsible if we provide a communal TV aerial.
Wall tiles	✓		Wall tiles you have installed.
Washers on taps	✓		
Washing machines (waste)	✓		If you provided the washing machine.
Water heating	✓		

Item	Us	You	Exceptions
Water supply (including cold or hot-water tanks and pipes)	✓		
Window fittings (including catches)	✓		
Window frames	✓		
Window sills	✓		
Woodwork at roof level	✓		

Please note

If you are a secure tenant, you have the right to improve or alter your home, as long as you get our written permission first. But you will be responsible for the repair, maintenance and servicing of any items you have installed and for replacing them when they wear out. If you have a non-secure or introductory tenancy, you do not have the right to improve or alter your home.

Compliments and complaints

We welcome feedback about any aspect of the service you have received. You can contact us by email or through our website or in person, by telephone or letter.

Repairs we can charge you for

We do not pay the cost of all repairs to your home. If you or your visitors have caused damage (for example, broken a window) or been negligent (for example, lost your keys), we will do the work but will charge you for it. We will tell you that we will charge you for a repair and then send you an invoice. You may be able to pay the invoice in instalments, or claim back the cost of getting a repair done through your personal contents insurance. It is up to you to check your policy details to see if you are covered for accidental damage.

Right to Repair scheme

As part of the Government Citizens' Charter, the Right to Repair scheme was introduced in 1994. Certain qualifying repairs, usually small urgent repairs that cost under £250, will be done within set timescales. If they are not done within these timescales, you can ask us to arrange for another contractor to do the work.

The Right to Improve your Home

If you are a secure tenant, you may make improvements to your home but:

- you must obtain written permission from us before you make the improvement;
- you must meet any planning permission and building regulation rules that apply; and
- you must keep to any conditions that we set when we give you our permission.

You will be responsible for any future repair, maintenance and servicing, of any improvements you make and for replacing them when they wear out.

The Right to Compensation for Improvements

If you are a secure tenant and you decide to end your tenancy, you may be eligible for compensation for certain improvements you have made.

Examples of eligible improvements include:

- installing a bath, shower, washbasin or toilet; and
- installing a kitchen sink or work surfaces for preparing food.

The Right to Buy

Most secure council tenants have the Right to Buy their home if they have lived in certain types of accommodation for a specific period. Once you have applied to buy your home we will only carry out essential repairs to it and we

will remove it from ongoing and planned programmes of improvement works.

How to use the following pages

What is the fault and its number?

When you contact us to request a repair, we will be able to process it more quickly and efficiently if you use the diagrams on the following pages.

When reporting your repair please tell us:

- the page number;
- the section title;
- the number next to the item; and
- the description that matches the type of repair you need.

Basins

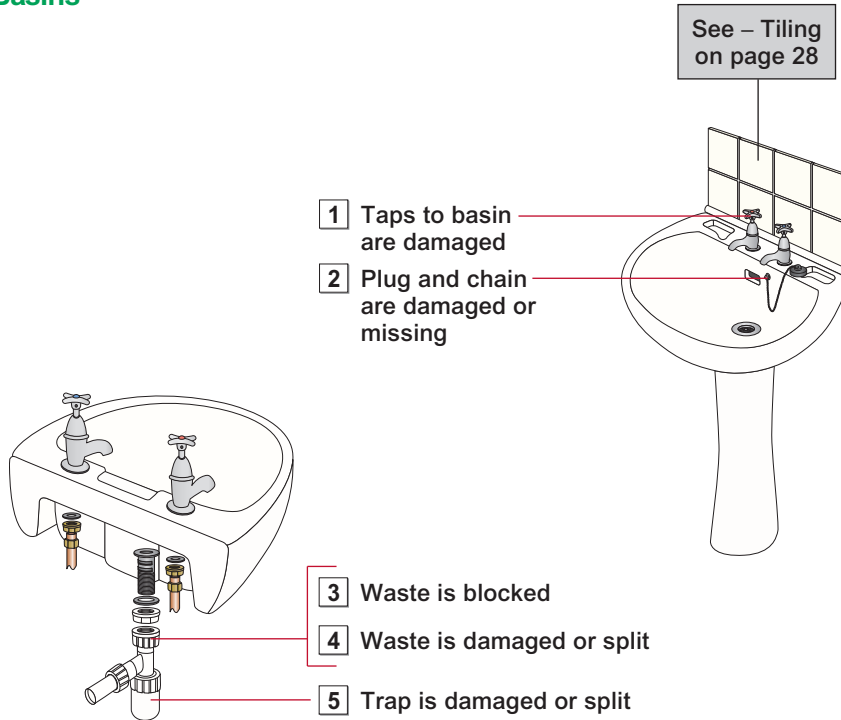

We need to know ...

Tap dripping or faulty

- Which tap, basin or sink?
- What is the problem – tap dripping, seeping or broken?
- Is it a cold or hot tap?
- Is it running as if fully on?
- Is it a lever handle tap?

Leaks

- Is the supply pipe for hot or cold water?
- Can the water be turned off at the stop tap?
- Are the electrics affected?

Basin loose or damaged

- Is it on brackets or a pedestal?

Sinks

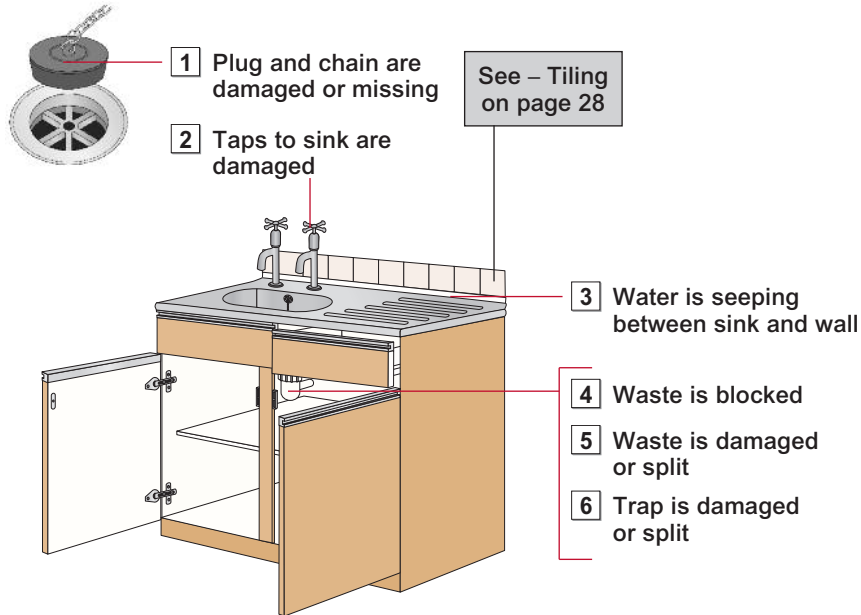

We need to know ...

Tap dripping or faulty

- Which tap, basin or sink?
- What is the problem – tap dripping, seeping or broken?
- Is it a cold or hot tap?
- Is it running as if fully on?
- Is the tap on but there is no water?
- Is it a lever handle tap?

Leaks

- Is the supply pipe for hot or cold water?
- Can the water be turned off at the stop tap?
- Are the electrics affected?

Sink loose or damaged

- What is the problem – unit coming away from wall, top loose on base unit, or base unit falling apart?

Baths

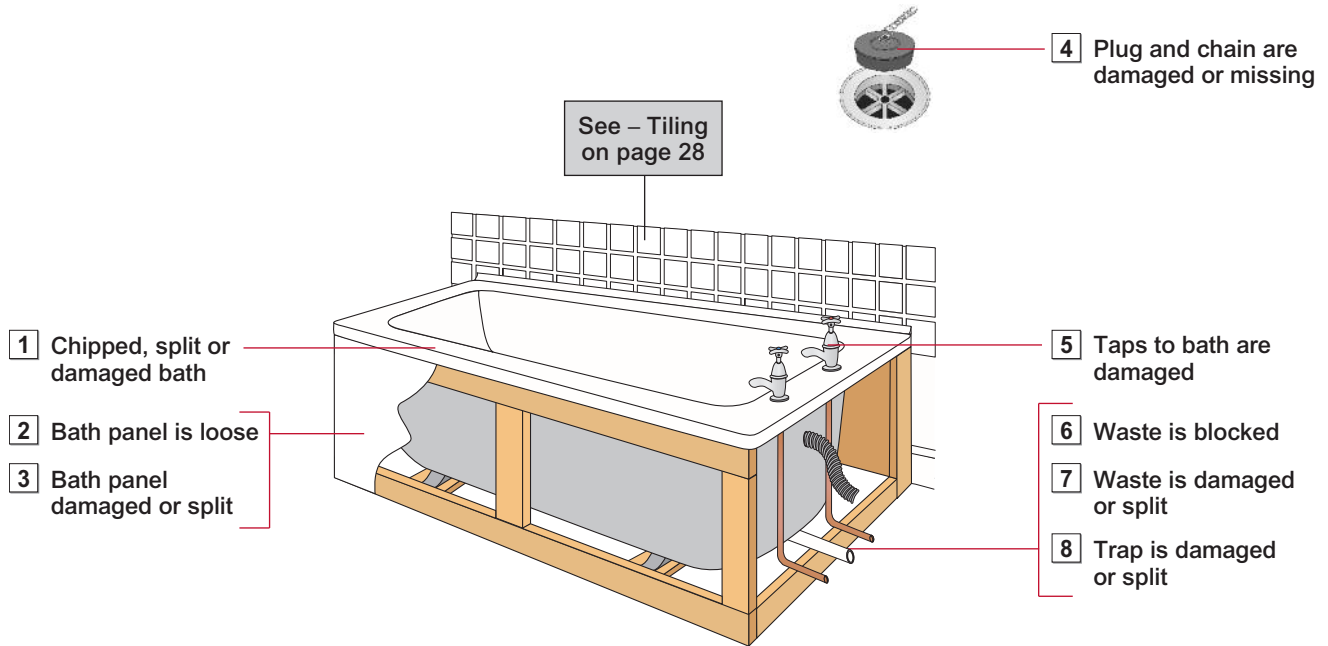

Showers

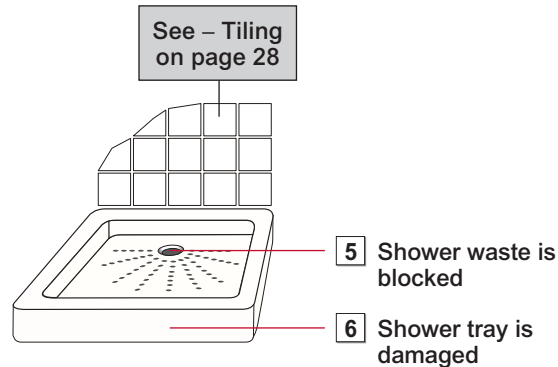
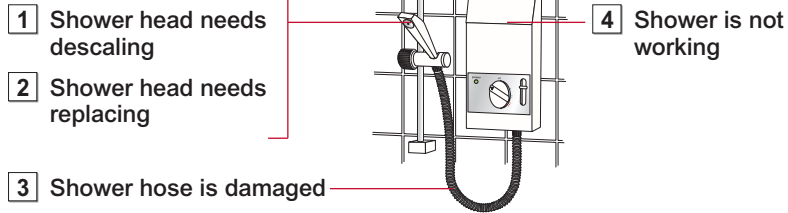

We need to know ...

Taps

- Can the tap be turned off?
- Do you know where the stop tap is?

Bath damaged

- Is it chipped, cracked, loose or broken?
- Is it plastic or pressed steel?

Bath or shower seal faulty or leaking

- Is the leak showing on a ceiling?
- Are the electrics affected?

Shower not working

- Make and model of shower?
- Did you install it yourself?
- Is it electrically operated?
- Is a part broken, for example, the shower head, hose, tray or cubicle?

External door

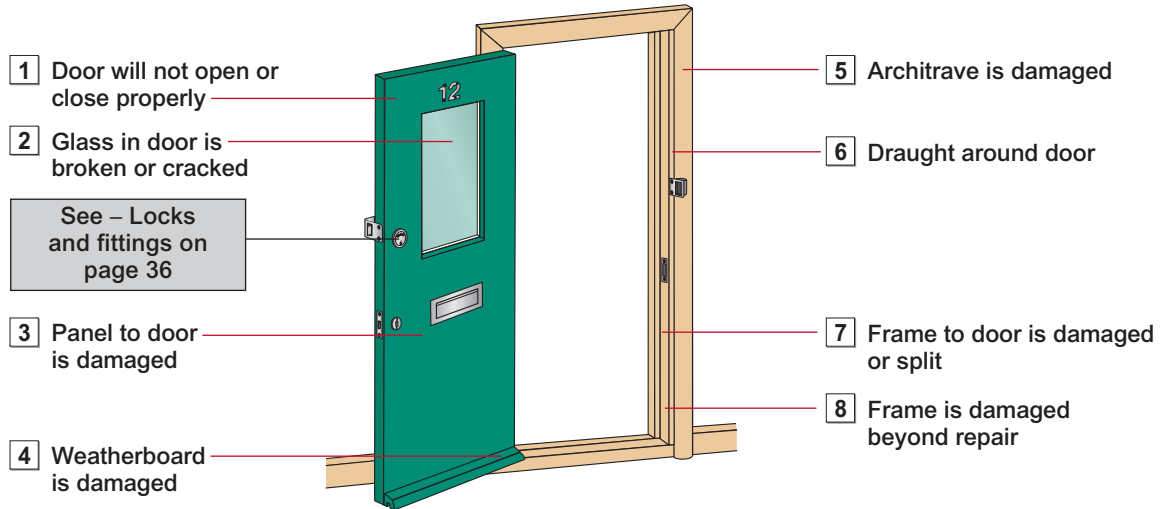

Internal door

1 Internal door is damaged or hanging off its hinges

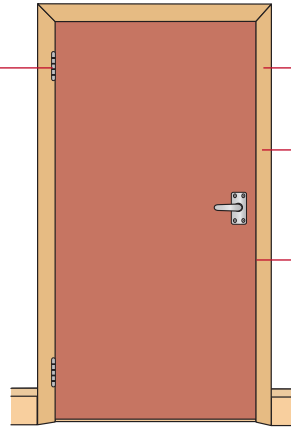

4 Part of architrave is loose

5 Part of architrave is damaged

6 Frame to door is damaged or split

7 Frame to door is damaged beyond repair

2 Door stop is loose

3 Door stop is damaged

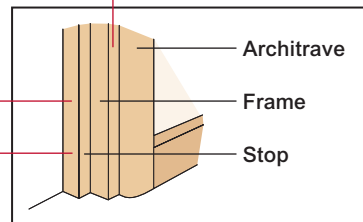

We need to know ...

External door

- Is the problem with the door or lock?
- Is the frame damaged?
- Are the premises secure?
- Has there been a forced entry?
- Do you have a crime number from the police?
- Has the door been recently painted?
- Do you have another access?

Internal door

- If the door is off its hinges, can it be stored in a safe place?
- Is the door sticking?
- Have new carpets been fitted?

Downpipes

- 1 Part of downpipe is damaged or missing – one-storey property
- 2 Part of downpipe is damaged or missing – two-storey property
- 3 PVC bracket to downpipe is damaged or missing
- 4 PVC running outlet is damaged or missing
- 5 Rainwater or downpipe clip is loose
- 6 Downpipe is blocked

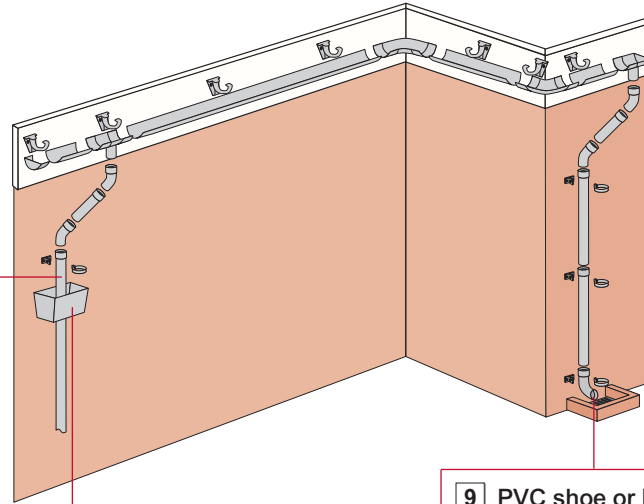

- 7 Hopperhead is blocked
- 8 PVC hopperhead is damaged

- 9 PVC shoe or bend to downpipe is damaged or missing
- 10 Gully is blocked

Gutters

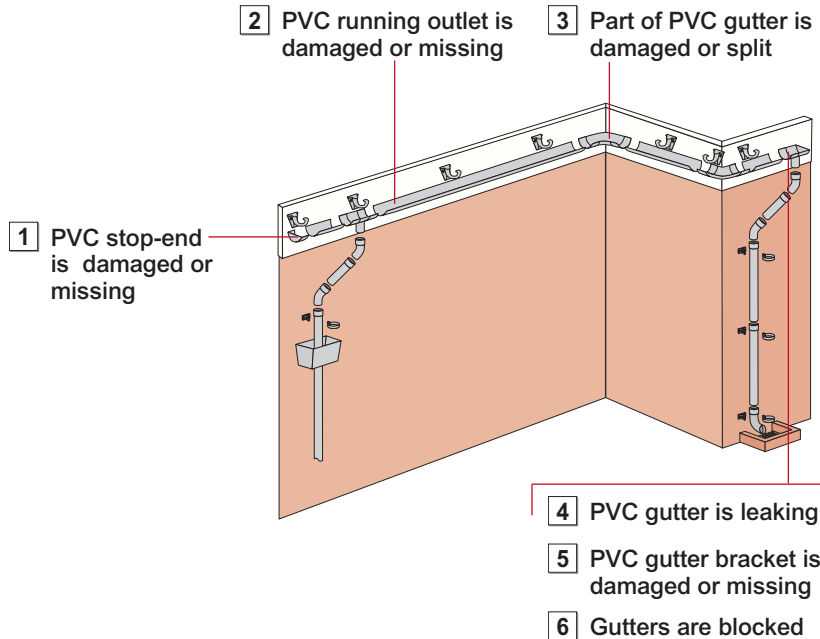

We need to know ...

Downpipe leaking or blocked

- What are the downpipes made of?
- Is the leak on the downpipe leading from the roof to the drain?
- Do you have any problems with soiled water backing up in a toilet or garden?

Gutter leaking

- Where is the leak?
- Is the leak where there is a joint?
- Have any sections of the gutter broken away?
- Are the gutters to a one-storey property or two-storey property?
- What are the gutters made of?

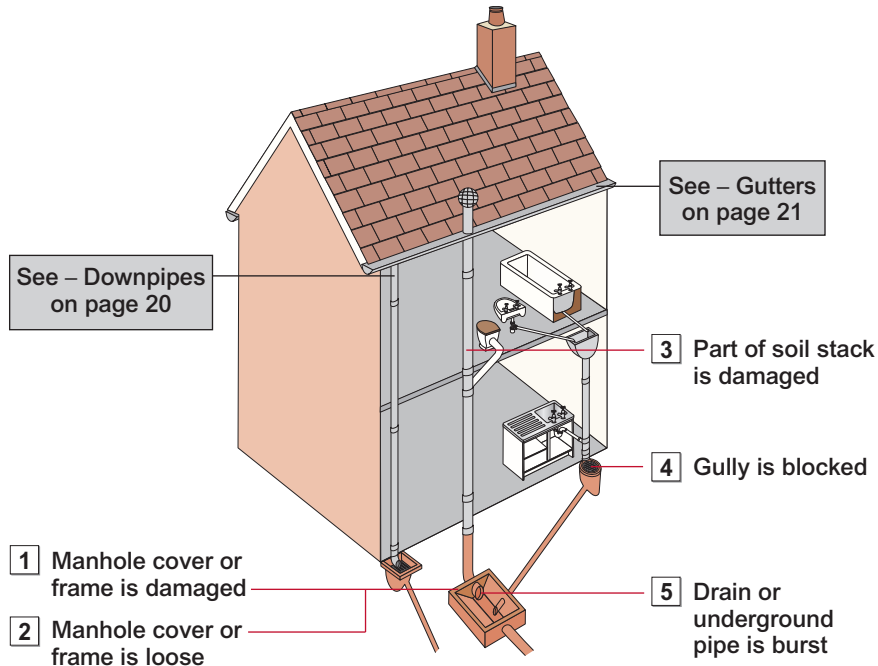

We need to know...

Blocked drain

- Is it affecting the toilet, bath, washbasin or sink?
- Is there a complete blockage or does the water drain away?
- Is there any water lying outside?
- If there is water lying outside, is it where the waste or rainwater pipe drains away, or is it coming from the manhole?
- Is the manhole within the boundary of your property? If so, can we gain access to it?
- Is there any evidence of sewage? If so, where?

Light fittings

- 1 Bulkhead light is not working

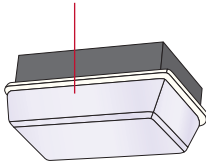

- 2 Ceiling rose and fitting is damaged

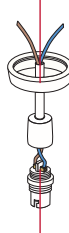

- 3 Batten light fitting is damaged or not working properly



- 4 Pendant light fitting is damaged or not working properly

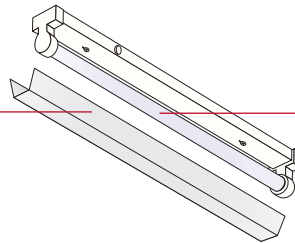

- 5 Single fluorescent light fitting is damaged

- 6 Single fluorescent tube is damaged

Power sockets and spurs

Single gang socket

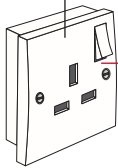

Double gang socket

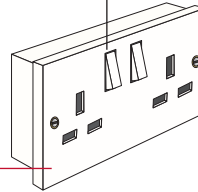

- 1 Socket outlet plate is broken – single gang
- 2 Socket is broken – single gang
- 3 Socket outlet plate is broken – double gang
- 4 Socket is broken – double gang

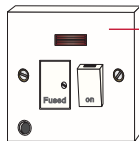

- 5 Fused spur is damaged
- 6 Cooker control unit is damaged

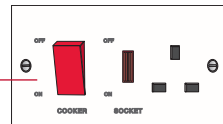

We need to know ...

Faulty lights

(See diagrams on page 23 and 25.)

- Are all lights affected? If not, which room is the faulty one in?
- Do you know where the consumer unit (electricity meter) is with the trip switches and fuses?
- Can you reset the trip switch?
- Is it a shared area?
- Have you fitted your own light(s) recently?

Faulty sockets

- Are all sockets affected? If not, which room is the faulty one in?
- Do you know where the consumer unit (electricity meter) is?
- Can you reset the trip switch?
- Is the socket surface-mounted or flush-mounted (cut into and flush with the wall)?
- Have you fitted your own socket(s) recently?

Light switches

1 Single gang, one-way light switch is damaged

2 Single gang, two-way light switch is damaged

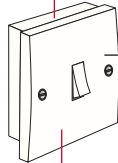

Single gang switch

3 Single gang switch plate is damaged

4 Double gang, one-way light switch is damaged

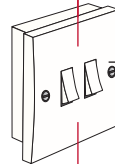

Double gang switch

5 Double gang switch plate is damaged

6 Time switch is not working properly

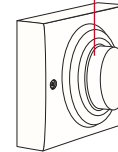

Explanation

A double gang switch is two single switches wired into one face plate. A two-way light switch allows one light to be switched on and off independently of the other switch. An example of this is a hallway and stairs, where the lights can be turned on upstairs, and turned off from downstairs. Other examples of two-way light switches occur in rooms that have two doorways, with a light switch at each door, or bedrooms that have a main light switch and a switch within reach of the bed.

Extractor fans and smoke detectors

1 Extractor fan is not working properly

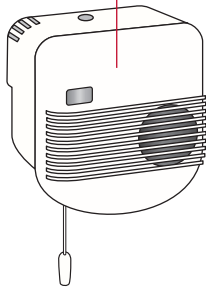

2 Mains smoke detector is broken or sounding constantly

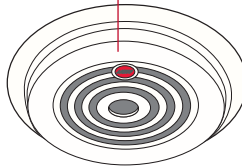

We need to know ...

- Is the smoke alarm upstairs or downstairs?
- If you have two, are they both sounding constantly?

Floor, wall and ceiling repairs

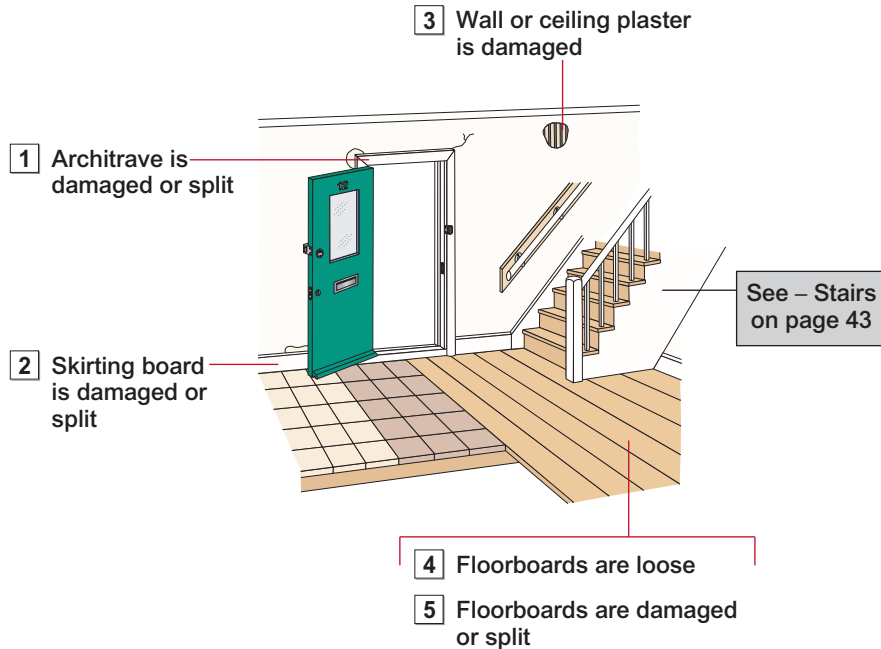

We need to know ...

Wall plaster damaged

- Which room is it in?
- How did it happen?
- How much is affected?

Ceiling plaster damaged

- Which room is it in?
- Are the cracks hairline, small or large?
- Are there any stains or water leaks?

Tiling

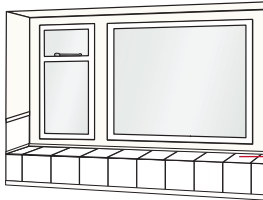

1 Wall tiles are loose

2 Wall tiles are damaged or missing

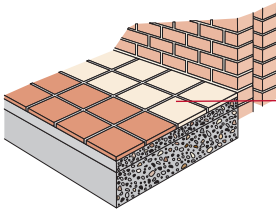

3 Quarry floor tiles are damaged or missing

4 PVC floor tiles are damaged or missing

5 Non-slip finish flooring is damaged

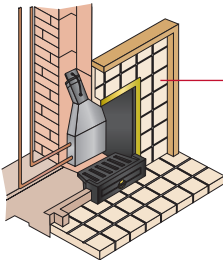

6 Tile to fireplace is damaged

We need to know ...

Tiles

- What room are they in?
- How many tiles are broken or missing?
- What colour are the tiles?
- What are they made of?
- Is it a shared area?

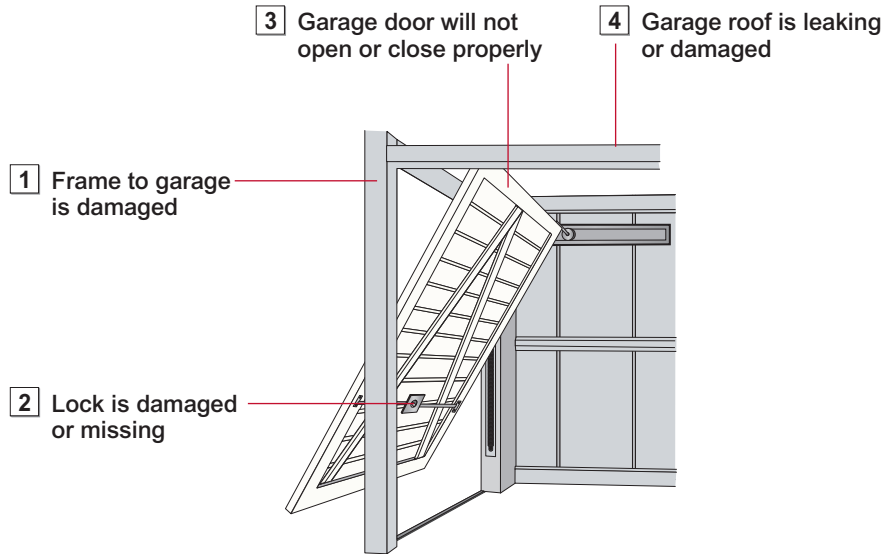

We need to know ...

- What is your address, telephone number or email address?
- What is the address of your garage?
- Is your garage door wooden or metal?
- Is the roof leaking or damaged?
- Is the lock or a cable broken?
- Is the frame loose?

Double glazing

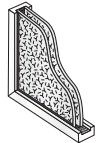
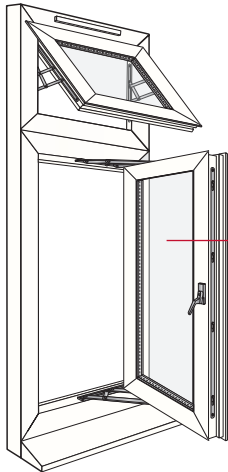

Obscure
double-glazed

- 1 Very small pane of clear double-glazed glass is broken
- 2 Very small pane of obscure double-glazed glass is broken
- 3 Small pane of clear double-glazed glass is broken
- 4 Small pane of obscure double-glazed glass is broken
- 5 Medium pane of clear double-glazed glass is broken
- 6 Medium pane of obscure double-glazed glass is broken
- 7 Large pane of clear double-glazed glass is broken
- 8 Large pane of obscure double-glazed glass is broken

We need to know ...

- How did it happen?
- Do you have a crime number from the police?

Double glazing damaged

- How did it happen?
- Is the broken pane inside or outside?
- Which room is it in?

Single glazing damaged

- How did it happen?
- Which room is it in?

Single glazing

- 1 Very small pane of clear glass is broken
- 2 Small pane of clear glass is broken
- 3 Medium pane of clear glass is broken
- 4 Large pane of clear glass is broken
- 5 Small pane of Georgian-wired glass is broken
- 6 Medium pane of Georgian-wired glass is broken
- 7 Large pane of Georgian-wired glass is broken
- 8 Small pane of Georgian-wired polished glass is broken
- 9 Medium pane of Georgian-wired polished glass is broken
- 10 Large pane of Georgian-wired polished glass is broken

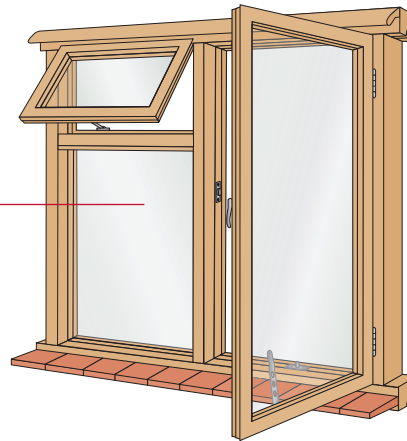

Obscure
single glazed

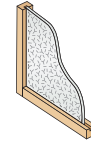

Georgian-wired
single glazed

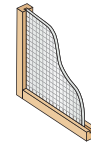

Airing cupboard

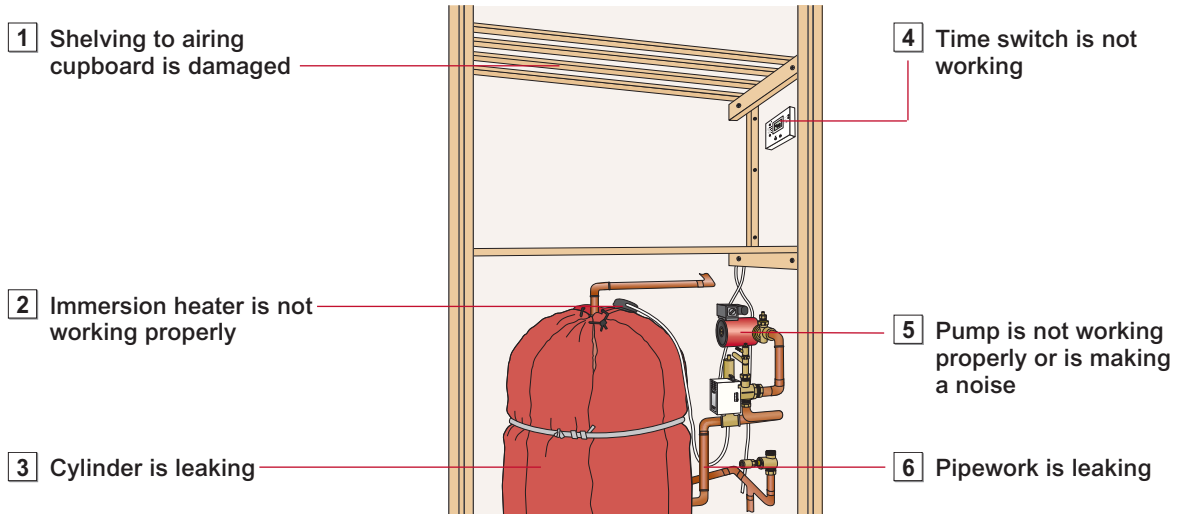

Heating



1 Room thermostat is not working properly

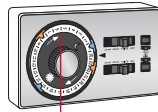

3 Time switch is not working properly

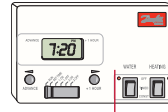

6 Programmer is not working properly

2 Night storage heater is not working properly

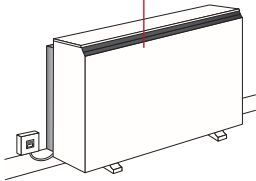

4 Radiator valve is not working properly

5 Thermostatic radiator valve is not working properly

7 Radiator is leaking, not working, or hot at the bottom but cold at the top

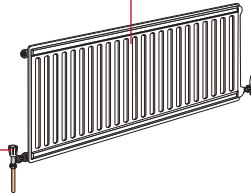

8 No heating

We need to know ...

No heating

- Are there any very young or very old people in the property, or anyone with a serious illness or disability?
- What type of heating do you have?
- Do you have heating in any of your rooms?
- Have you got alternative heating?

No hot water

- Is your water heated by gas or electricity?
- Do you have hot water at any time?
- Do you have an immersion heater?
- Do you have an alternative system for temporarily heating water?

Hot water

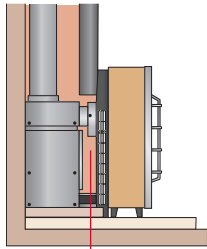

1 Back boiler is not working properly

2 Conventional flue boiler is not working properly

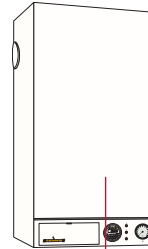
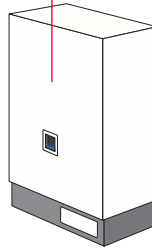

3 Combi boiler is not working properly

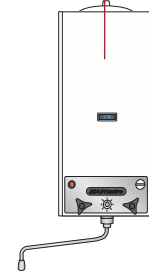

4 Multipoint water heater is not working properly

5 Knocking sound from water system

6 Hot water is unusually hot or there is a bubbling noise from the hot-water cylinder

7 No hot water

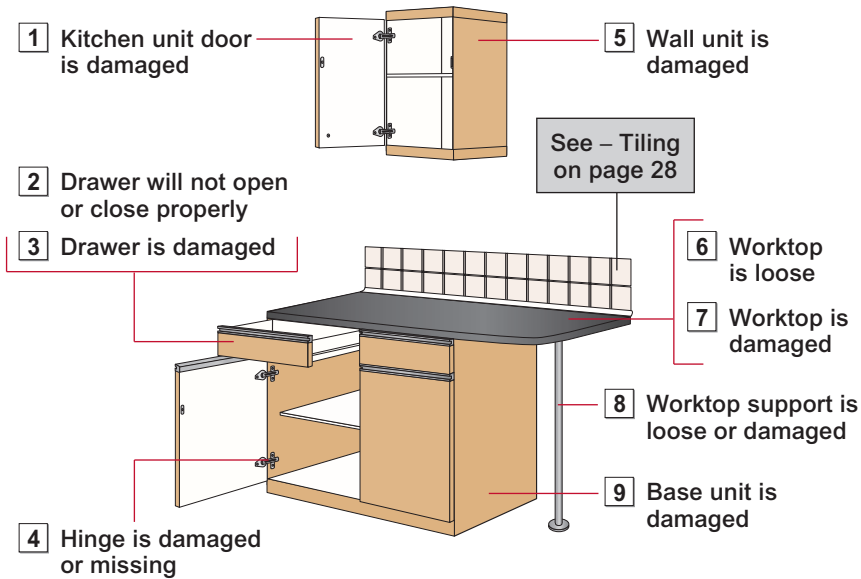

We need to know ...

Cupboards broken or damaged

- What is the cupboard used for and is there a manufacturer's name on it?
- What part of the cupboard is broken?
- How did the damage happen?
- What colour is the worktop or cupboard?
- Did you install the cupboards?
- Is it a double or single kitchen unit?

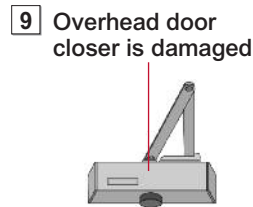
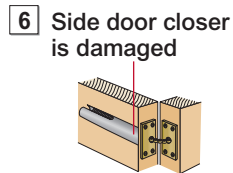
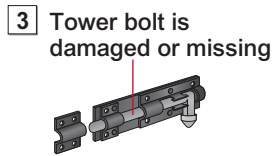
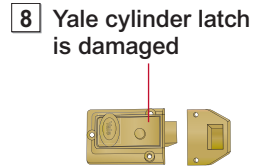
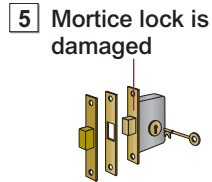
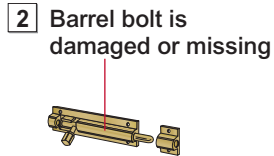
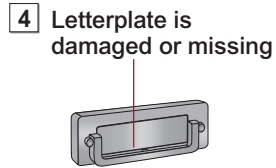
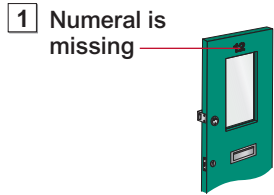

10 Any other type of lock not working properly

We need to know ...

- Can you tell us which door the lock or fitting is part of?
- Where is it?

Fences

1 Concrete post is damaged

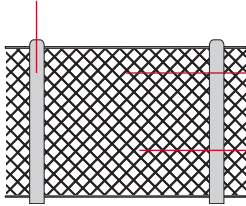

3 Chainlink fence is loose

4 Chainlink fence is damaged

7 Wooden post is damaged

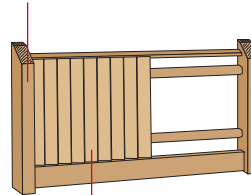

2 Feather-edge fence board is damaged

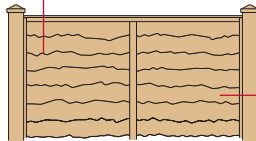

5 Paling fence is damaged

6 Fence panel is damaged

8 Slatted fence board is damaged

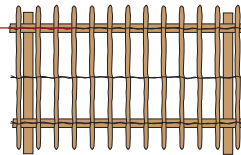

We need to know ...

Fence

- Where is it?
- What is it made of?
- How high is it?
- Did you install it yourself?

Gates

1 Gate catch is damaged or missing

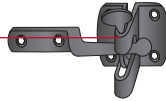

5 Suffolk latch is damaged or missing

2 Wooden gatepost is damaged

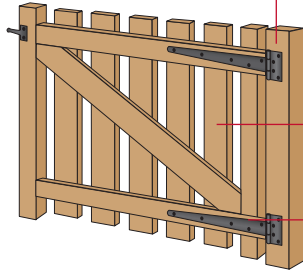

3 Gate pales are loose

4 Gate will not open or close properly

6 Concrete gatepost is damaged

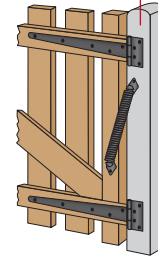

Walls, paving and steps

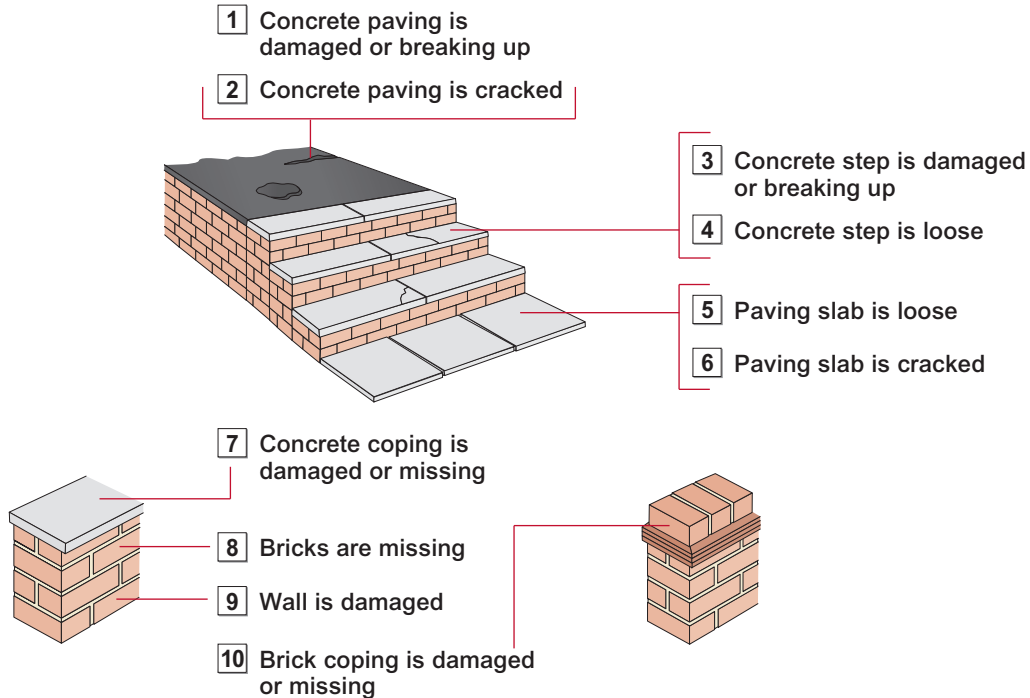

Clothes driers

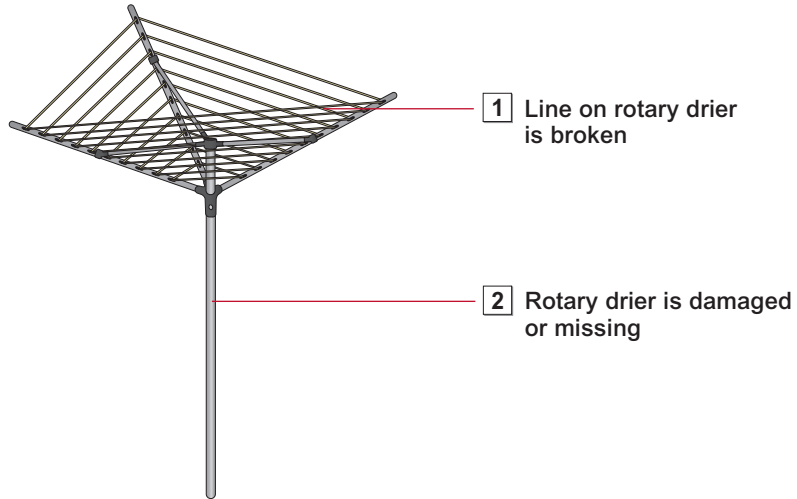

Roof and chimney repairs

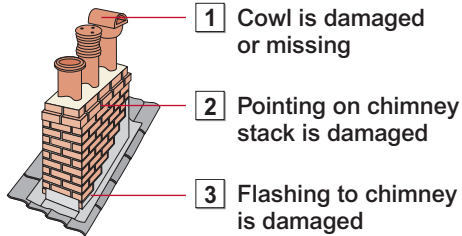

6 Lead flashing is damaged

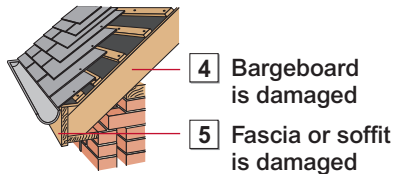
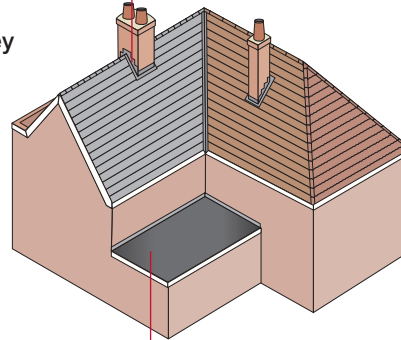

We need to know ...

Leaking roof

- Are any ceilings stained and if so, which rooms are these in?
- Is it a flat or pitched roof? If a pitched roof, is it covered in slates or tiles and are any of them missing or slipped?
- Are the slates or tiles missing from the front or back?
- Are the electrics affected?
- What floor or storey is the roof above?
- Can you see the damage from the ground?

Tiles and ridges

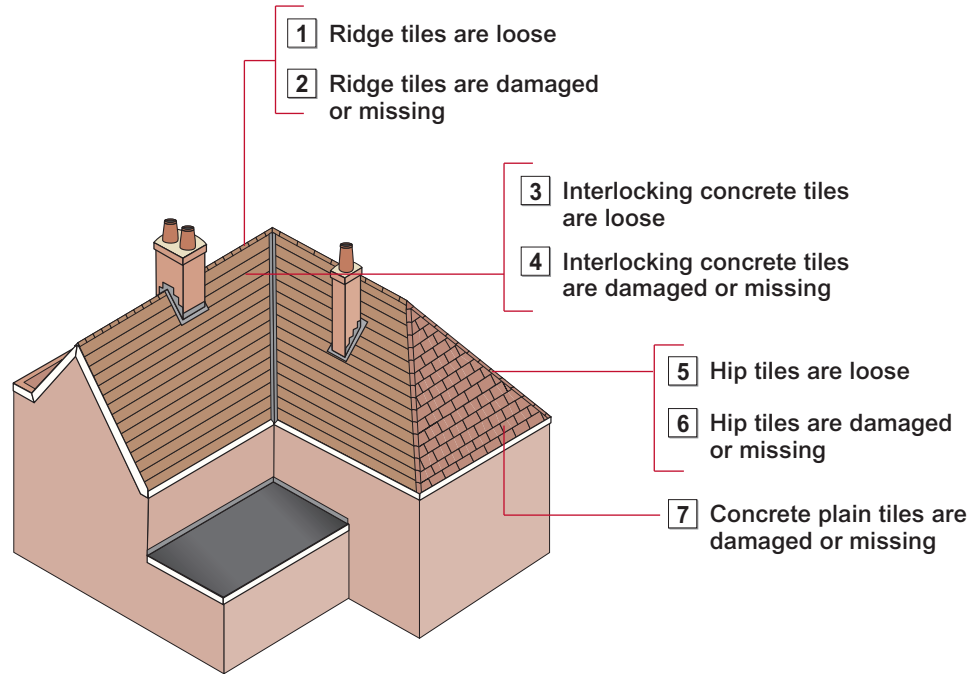
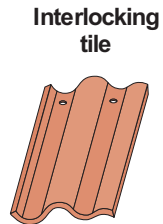
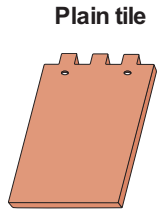

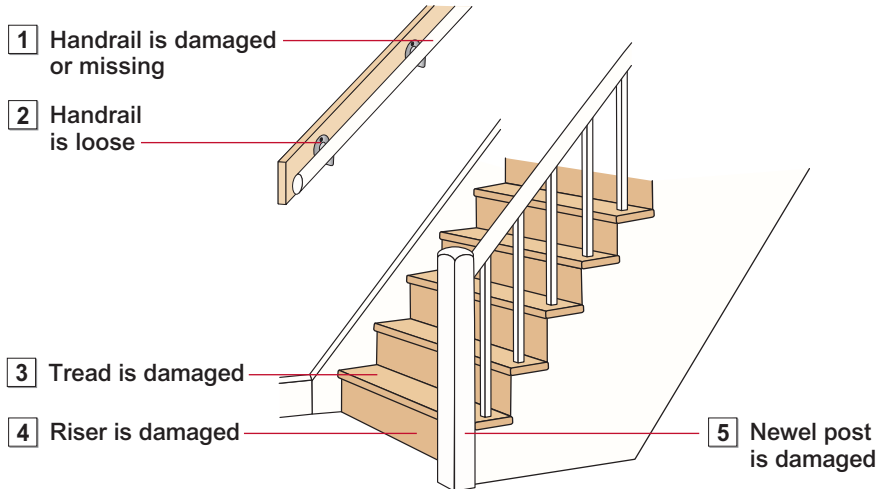
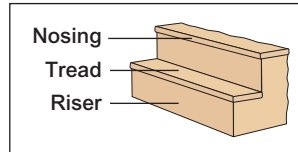

We need to know ...

Stairs

- How many treads or risers are affected?
- Is it a shared area?

Handrails

- Is the handrail on the wall or is it part of the staircase?
- Are the wall brackets broken?
- Is the plaster affected?

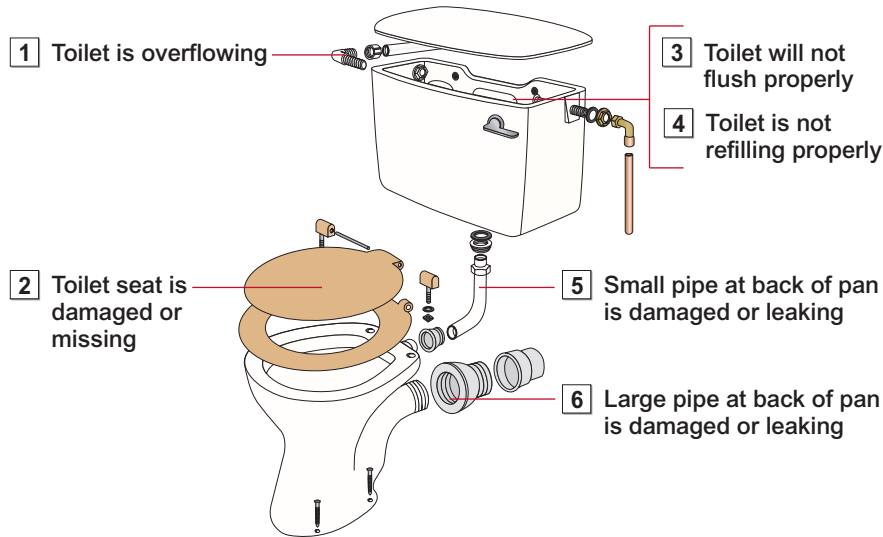

We need to know ...

Toilet broken or damaged

- Is it the pan or the flushing system? If it is the pan, is it cracked or is there a joint or pipe leaking?
- Is the toilet securely fixed to the floor?
- Is there another toilet in the home?

Overflow

- Is it running continuously?
- Does it flow outside or into a sink, a washbasin or the toilet bowl? If it flows outside, is the overflow at the front or back of the property?

Toilet not flushing

- Is the cistern filling up?
- Has the water supply been turned off?
- Is the handle broken?

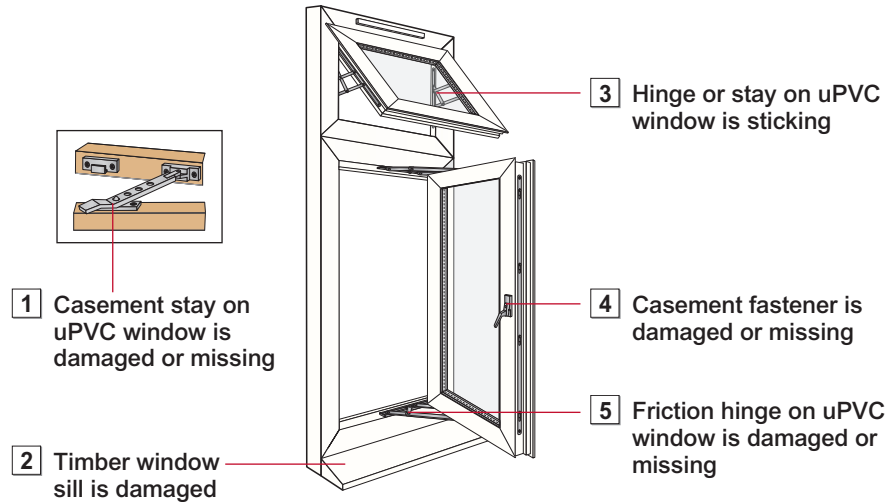

We need to know ...

Broken window

- What room is the window in?
- Which floor is it on?
- Are you able to close the window securely?
- Is the stay or fastener broken?
- Is the window timber, uPVC or another material?

What is condensation?

Condensation is simply water vapour in the air, condensing (or changing into) water on windows, walls, floors, even clothing or cupboards. There is always some moisture in the air, even if you cannot see it. If the air gets colder, it cannot hold all of the moisture and tiny drops of water appear. This is condensation.

What causes condensation?

Condensation can occur because your home is too cold. Condensation can also occur because your home is poorly ventilated, maybe when you shut all the windows and vents, or don't use extractor fans.

Condensation can also happen when your home is too wet. Maybe you dry clothes on radiators, or use a tumble dryer without a vent to the outside, or use portable gas heaters.

Condensation and mould growth

There are several things you can do if you have a problem with condensation in your property:

- Leave the heating on a low setting during cold weather.
- Wipe down windows, sills and frames where condensation occurs but do not leave the cloth on a radiator to dry.
- When cooking keep the kitchen doors closed and open a window slightly to allow ventilation.
- When taking a bath or shower keep the doors shut and the window open slightly to avoid moisture spreading through the house.
- Wherever possible dry clothes outdoors, not on radiators, and if you have a tumble dryer make sure it is vented to outside the property so that the moist air does not build up in your home.

- Do not use portable gas or paraffin oil heaters as they produce very large amounts of moisture.
- Try to move furniture so that the area behind your wardrobes and cupboards is well ventilated, and preferably against an internal wall. Try not to overfill them as this prevents air circulation.

You can usually identify dampness as an area of brown staining on walls. Staining on the lower walls may indicate rising damp, which occurs where the damp-proof course is defective or is covered by a pathway or garden. Leaking plumbing or broken pipes can also cause dampness. If you think you have dampness, please contact us and a surveyor will call to investigate.

How to guard against frost

At the beginning of a cold spell:

- keep the property warm at all times;
- let the warm air circulate; and
- make sure you know where the main water control tap or stop valve is, and how to turn it off (if it does not work properly, ask us to repair it).

If you leave your home empty when the weather may turn cold, and there is a danger of hard frost, you should protect your home against water damage from burst pipes.

When you return home:

- Turn the stop valve on again and make sure enough water comes out of your taps. This is to check there is no air in your pipes.
- If you have switched on your central heating, but the radiators are not getting hot, turn the system off and tell us. First check the timer is working and the pilot light is lit.
- If one radiator stays cold or only heats at the bottom, you probably need to bleed the air out with a radiator bleed key.

If you have any problems doing this, please contact us.

What to do if you get a frozen pipe

- Turn off the water immediately at the stop tap.
- Switch off any immersion heater.
- Turn off all taps.
- Contact us.
- Do not try to thaw frozen pipes with a naked flame.

What to do if you have a burst pipe

- Turn off the water immediately at the stop valve.
- Turn on all the taps to drain the water as quickly as possible from the system to stop it flooding your home.
- Find out where the water is coming from.
- Put a container underneath to catch any leaks.
- Contact us for advice before you turn on the water.

If there is any water coming through light fittings or ceiling roses, do not turn on the light. Contact us immediately.

What to do if you have a gas leak

If you smell gas

You should immediately:

- put out any cigarettes or naked flames;
- open all doors and windows;
- check if a pilot light has gone out or if a gas tap has been left on; and
- turn the gas off at the meter (see diagram above) and phone the National Gas Emergency Service on 0800 111 999.

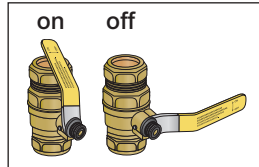

Do not:

- turn the supply back on or try to use any gas appliances until the leak has been repaired;
- use matches or a naked flame; or
- turn on any lights or sockets.

Gas safety checks

By law we must check all gas appliances we have provided every 12 months to ensure they

are safe. You must allow us access into your property to carry out these checks.

We will write to tell you when we will be coming out. If you are out when the engineer calls, they will leave a card with a new appointment date and their contact details if this is not convenient for you.

Carbon monoxide

Carbon monoxide is a very poisonous gas that can kill quickly. You cannot see it or smell it, but if you breathe it in you will rapidly become tired and dizzy, possibly with head and chest pains.

To reduce the risk of carbon monoxide poisoning, make sure that you allow us access to service any gas appliances we have provided and arrange for any of your own appliances to be checked as well. You should also keep your home well ventilated and never block up your vents with furniture or wallpaper.

Central heating servicing

By law we must get all our gas appliances and pipework inspected and serviced every 12 months, and we also service electric, oil and solid-fuel heating appliances regularly.

This service and safety check benefits you in three ways:

- A regularly serviced and well-maintained appliance will work more efficiently and save

you money on your heating and hot water bills.

- The safety check reassures you that your appliance is working safely.
- A regularly serviced and well-maintained appliance is less likely to break down.

The engineer will also check your smoke detectors and report any faults.

Checklist if your central heating is not working

Please check:	Yes	No	If No, what to do:
Is the boiler switched on?	<input type="checkbox"/>	<input type="checkbox"/>	Switch on the boiler.
Do you have gas or oil?	<input type="checkbox"/>	<input type="checkbox"/>	Put credit in the meter.
Do you have electricity?	<input type="checkbox"/>	<input type="checkbox"/>	Put credit in the meter or wait for power to be restored (power cut).
Do you have water?	<input type="checkbox"/>	<input type="checkbox"/>	Do your neighbours have water? If not, phone the water authority.
Is your time clock showing the correct time?	<input type="checkbox"/>	<input type="checkbox"/>	Adjust the time according to the instructions for your time clock.
Is your room thermostat turned too low?	<input type="checkbox"/>	<input type="checkbox"/>	Turn up the room thermostat.
Is the pressure gauge in the green section?	<input type="checkbox"/>	<input type="checkbox"/>	Repressurise according to boiler instructions (if not sure, contact us).
Is the pilot light on?	<input type="checkbox"/>	<input type="checkbox"/>	Relight the pilot light according to boiler instructions.
Check done, all Yes, still not working?	<input type="checkbox"/>	<input type="checkbox"/>	Please report the problem to us.

Please tell us if you have any special needs (for example if you are an older person or someone with disabilities, or if you have young children) so we can prioritise the work. We will supply temporary heating if you need it.

Fire safety

Take precautions

- Never leave cigarettes burning.
- Never smoke in bed.
- Keep matches away from children.
- Never leave a chip pan unattended.
- Regularly check electrical fittings and flexes.
- Test any smoke alarm weekly by pressing the test button.
- Plan how you and your family would get out in a fire and practise it with your family.
- Make sure your door and window keys are nearby.
- Close the doors in your home at night.

If fire breaks out

- Use the escape route you have planned.
- Never enter a room if you think there is a fire inside.
- Close all inside doors to stop the fire spreading.

- Get everyone out of the building as quickly as possible.
- Phone 999 and ask for the fire brigade.

If you have an electrical fault and have lost your supply

- Check with neighbours to see if there is a power cut in your area. If there is a power cut, you will need to contact your electricity provider.
- If there is not a power cut, the fault is with your system.

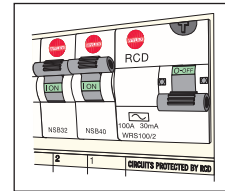

Your main electric switch may now include an automatic switch-off device called a residual current device or RCD (see diagram above) that protects you against electric shock or fire by switching off as soon as there is a fault.

- This switch or button will be next to or part of the main fuse board and should be switched back on to reset.

- If it will not reset, then the fault remains within the system.
- Switch off each individual fuse in turn and try resetting this switch one by one, until the power comes back on. This will tell you which circuit the fault is on.
- If a circuit fails, an appliance could be faulty. To find out which one it is, unplug all appliances on that circuit, switch the circuit back on and reset the trip switch.
- Plug in each of the appliances in turn. The power will switch off again when you plug in the faulty appliance.
- Disconnect that appliance and ask a suitably qualified electrician to check it.

If you receive a shock from either a switch or a socket, please contact us immediately. You must not use the switch or socket, and you should turn the circuit off at the fuse box or circuit breaker.

For essential electrical safety

- Do not have too many items plugged into one socket.
- Do not have more than 13 amps on each socket.
- Check flexes and plugs regularly to make sure they are not damaged.
- If fuses keep blowing or if you get an electric shock from an appliance, a qualified electrician should check the appliance for you. If we provided the appliance, please contact us immediately.

Resetting a trip switch

General advice

Modern electric circuits are fitted with a circuit breaker fuse system. If a fault develops, a switch is tripped and the circuit is broken.

All the fuses and trip switches are in the consumer unit. The consumer unit may be next to the electricity meter (unless the meter is in an outside cupboard).

Trip switches usually operate because:

- a circuit has been overloaded with too many appliances being used at the same time;
- an appliance is faulty or misused;
- a light bulb has blown; or
- an immersion heater is faulty.

If an appliance is faulty, leave it unplugged and get a qualified electrician or service engineer to check it.

If a wall or ceiling light is faulty, keep it switched off (put some tape over the switch) and contact us.

What to do

- Open the cover on the consumer unit to expose the trip switches.
- Check which switches have tripped to the 'off' position.
- Put these switches back to the 'on' position.

If the trip goes again, it is probably being caused by a faulty appliance. You need to find out which circuit is being affected and which

appliance on that circuit is causing the problem.

To identify the faulty appliance

- Check all the rooms in the house and note which set of lights or sockets (circuit) is not working.
- Unplug all appliances on that circuit.
- Switch the 'tripped' switch to the 'on' position.
- Plug in the appliances and switch on the lights one at a time, until it trips again.
- Do not use adaptors or extension leads when testing appliances. Test one appliance for each socket, until the trip goes.

Never tamper with the electricity company's fuses and seals.

Smoke alarms

We have fitted mains-powered smoke alarms in all our properties. These will give you an early warning by making a loud noise if fire breaks out. Smoke alarms save lives. If

you have a hearing impairment and you cannot hear a smoke alarm, please let us know and we will adapt the alarm for you.

Looking after your smoke alarms

Do

- Test it regularly. You can do this by pressing the test button until the alarm sounds. The alarm should stop sounding after you take your finger off the button.

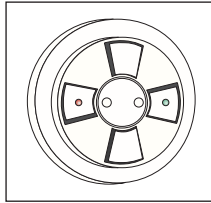

Do not

- Try to disconnect your alarm.
- Paint over it, or cover it.
- Move it.

Our heating contractor will check your smoke alarms each year, usually when they visit to service your heating system.

Blockages

Clearing blockages

Bale out most of the water using a suitable container. Hold a rag firmly over the overflow opening and place a plunger over the drain hole. Pump the plunger up and down rapidly. You can get plungers from most DIY shops.

Avoiding blockages

Air fresheners that attach to the rim of the toilet pan should be fastened securely to ensure they do not fall in and cause a blockage.

Blockages are usually caused by unusual objects – nappies, toys, sanitary towels, and air fresheners. If such a blockage occurs because of one or more of these objects, you may be charged for clearing the blockage.

If more than one fitting is blocked

The problem may be in the soil stack or main drain. This will need to be cleared by one of our contractors. Blockages are usually caused by the build-up of fat, tea leaves, hair and so on. It is advisable to clean wastes with hot water and a drain-cleaning product regularly.

Preventing Legionnaires Disease

Legionnaires disease is a kind of pneumonia, named after an outbreak of severe pneumonia that affected a meeting of the American legion in 1976. It is caused by water-borne bacteria that can be transferred to people by breathing in droplets of water contaminated with the bacteria. The symptoms of this illness are very similar to those of the flu and include a high temperature, cough, muscle pains and

headaches and these are treated with antibiotics. However, most people who are exposed to these bacteria do not become ill and the disease is rare.

Although cases of legionnaires disease are normally associated with large industrial water systems, it is possible for the bacteria to form in domestic water systems in certain conditions. We would therefore recommend you follow the advice given here to make sure your water system remains safe:

- Keep your cold water storage tank covered.
- Make sure any lengths of pipe, showers or taps that are not used regularly are flushed through frequently to remove any stagnant water.
- Regularly clean and disinfect any taps and shower heads in your home.
- Make sure taps and showers are flushed through following any periods when they have not been used to move any stagnant water, for example when you get home from holiday.

- Report any repairs that are needed to pipework, taps or showers in your home promptly and contact us if you have any concerns about the equipment installed in your home.
- Follow the advice that we give you if you apply for permission to install your own shower.
- If you have any concerns about the quality of your drinking water, Veolia Water East have an online Water Quality Guide that can be viewed by visiting their website or you can phone them on 0845 1489288.

Save £££s with these energy-saving tips

- Switch off your TV set when it is not in use. Leaving it on standby can use 50 per cent of the electricity that is used when it is fully switched on.
- Use low-energy light bulbs. They use less than a quarter of the energy of ordinary bulbs and they last 10 times longer.

- When replacing your fridge or freezer buy one with an 'A' grade for energy use.
- Turn the heating thermostat down a little. 1°C lower could save as much as 10 per cent on your fuel bill.

For further information on savings see the Energy Saving Trust website at this address www.energysavingtrust.org.uk

If a residual current device (RCD) or a miniature circuit breaker (MCB) trips because of a fault, you should take the following action.

If an RCD trips

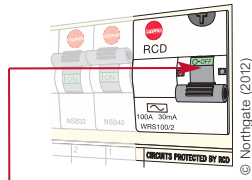

- Switch the RCD back on.
- If the RCD trips again, switch off all MCBs protected by the RCD.
- Switch on the RCD and each MCB in turn, until the RCD trips again.
- Unplug all electrical appliances on this circuit.
- To identify which is the faulty appliance, plug in each one in turn, until the RCD trips again.
- Unplug the faulty appliance and **do not use** it until you have contacted a qualified electrician for advice about its repair.
- Switch the RCD back on.

If you cannot identify the faulty appliance and you still cannot switch on the RCD, report an electrical fault.

If an MCB trips

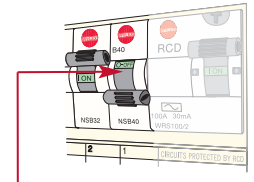

- Switch the MCB back on.
- If the MCB trips again, unplug all electrical appliances on this circuit.
- Switch the MCB back on.
- To identify which is the faulty appliance, plug in each one in turn, until the MCB trips again.
- Unplug the faulty appliance and **do not use** it until you have contacted a qualified electrician for advice about its repair.
- Switch the MCB back on.

If you cannot identify the faulty appliance and you still cannot switch on the MCB, report an electrical fault.

Where to find equipment

Please fill in the details in the box below. This information may be useful when you have to report a repair.

Item	Position in your home
Boiler	
Fuse box	
Gas on and off lever	
Stop tap (mains water)	
Trip switch or electricity meter	
Water tank	

Published in January 2012 for Tendring District Council by:

Northgate Information Solutions Limited

People Building, Maylands Avenue, Hemel Hempstead, Hertfordshire, HP2 4NW.

No part of this publication may be reproduced, stored in a retrieval system, or transmitted in any form, or by any means electronic or mechanical, including photocopying, recording or otherwise, without the prior written consent of Northgate Information Solutions Limited.